

SAM

- Scorrimento Angolare versione "M"
- Angled Undercut "M" version

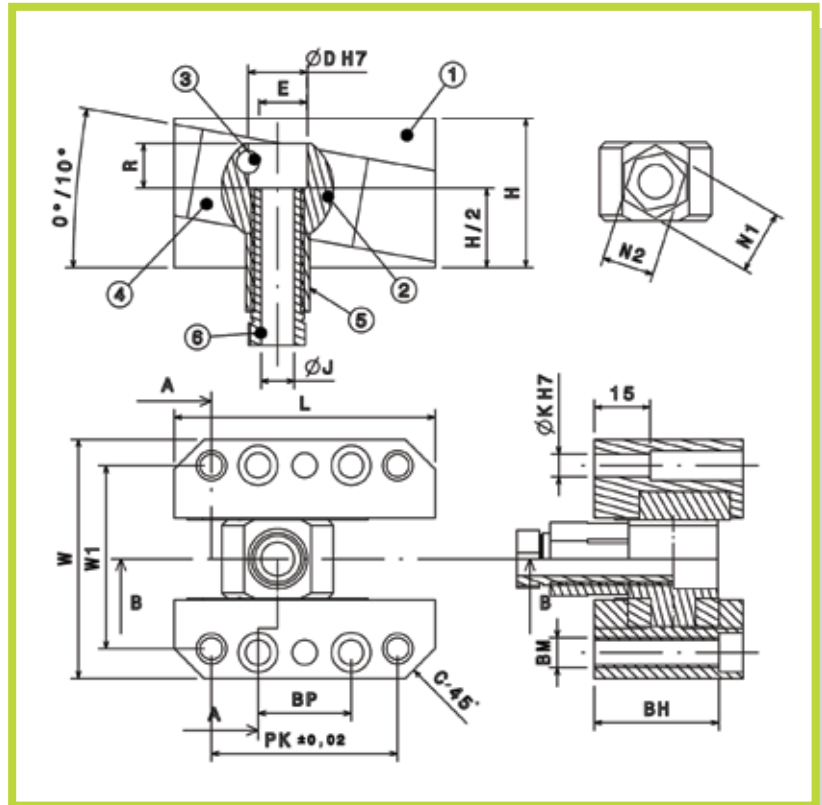

Parte Part	Note Notes
Slitta Carrier	2 pz./2 pc.
Bussola Inclinata Angled bush	1 pz./1 pc.
Spina Slot	1 pz./1 pc.
Guida sbarra Guide bar	2 pz./2 pc.
Ghiera di aggiustaggio Clamping ring for fit	1 pz./1 pc.
Ghiera di serraggio Clamping ring for serration	1 pz./1 pc.

Esempio di ordinativo: Codice + angolazione*
Example of purchasing order: Code + angle*

Codice Code	D	W	L	H	W1	BP	R	PK	K	BM	BH	E	J	C	T	d	N1	N2
SAM164050	16	64	70	40	50	25	12	50	Ø6	M8	33,5	13	9	6	45	9	17	14
SAM204660	20	76	75	46	60	30	15	55	Ø8	M10	37,5	17	11	8	45	11	22	19
SAM254865	25	81	85	48	65	40	17,5	65	Ø8	M10	39,5	22	13	8	50	14	27	22
SAM305472	30	88	100	54	72	50	19	80	Ø8	M10	45,5	27	13	8	60	14	32	27
SAM356080	35	100	115	60	80	50	20	85	Ø10	M12	49,5	31	13	8	70	14	36	32
SAM406588	40	108	125	65	88	50	21,5	85	Ø10	M12	55	36	17	8	80	18	41	38

*min. 0°, max. 10°
*min. 0°, max. 10°